



FLOW X

USER MANUAL

ACCESS

VERSION 1.0

© 2020 thyssenkrupp Stairlifts B.V. All rights reserved.

Specifications and illustrations are subject to change without prior notice.
thyssenkrupp Stairlifts B.V. will not accept liability for any alteration or typing error.

Subject to the exceptions provided by law, this publication and/or its contents may not be, whether entirely or partly, reproduced, copied, and/or published in print, by photocopying, on microfilm, electronically or in any other way without the prior written consent of thyssenkrupp Stairlifts B.V.

TABLE OF CONTENTS

1	Introduction	1
1.1	Manual	1
1.2	Symbols	1
1.3	Intended use	2
2	Safety	3
2.1	Safety warnings	3
3	Description	6
3.1	Stairlift	6
3.2	Controls	8
3.3	Optional features	11
4	Use	19
4.1	Unfolding the seat and sitting down	19
4.2	Adjusting the safety belt	28
4.3	Travelling with the stairlift	29
4.4	Emergency stop	30
4.5	Communication Module (optional)	31
4.6	Standing up and folding the seat	34
5	Maintenance	40
5.1	Cleaning the stairlift	40
5.2	Regular maintenance	40
5.3	Replacing the batteries of the call-and-park stations/attendant control	41
6	Signals	42
6.1	Signals on motor housing	42
6.2	Sound signals from motor housing	42
6.3	Signals on joystick user interface	42
6.4	Signals on call-and-park station	46
7	Technical data	47
8	Contact	48

1 INTRODUCTION

1.1 MANUAL

The manual describes all equipment that is available for the Flow X stairlift. Not all features may be available for the model installed in your home.

The terms “left”, “right”, “front” and “rear” are used to identify specific parts of the stairlift. The reference point is always your position as user, sitting on the stairlift.

The terms “parking point” and “charging point” commonly refer to the same item. When the action of parking is referred to, the term “parking point” is used. When the action of charging is referred to, the term “charging point” is used.

1.2 SYMBOLS



WARNING

“WARNING” means that (fatal) injury is possible if the instructions are not obeyed.



CAUTION

“CAUTION” means that damage to equipment is possible if the instructions are not obeyed.



NOTE

“NOTE” is used to give additional information.



CRUSH HAZARD

“CRUSH HAZARD” means finger entrapment is possible if the instructions are not obeyed.

1.3 INTENDED USE

The stairlift has been designed to transport one person up and down the stairs. The stairlift can be used for straight stairs and curved stairs. The stairlift is intended for indoor use only.

The stairlift operates with an electric motor that is powered by rechargeable batteries in the drive. The batteries are charged at the charging points at the top and bottom of the stairs or at intermediate floors. As an option, the batteries can also be charged at any additional charging point.

The stairlift can be operated in three ways:

- While you are seated on the stairlift, use the joystick user interface in one of the armrests.
- If the stairlift is not in the required place, use the call-and-park control stations on each floor to call the stairlift.
- In case the chair user is not capable of operating the stairlift themselves, use an attendant control (optional).

2 SAFETY

2.1 SAFETY WARNINGS

Thyssenkrupp Stairlifts B.V. is not responsible for injury or damage caused by not obeying the safety warnings in the manual.

2.1.1 USER

- Before you use the stairlift, read the manual carefully. Only use the stairlift if you know and understand the safety warnings and the operating instructions.
- An authorised technician will demonstrate how the stairlift operates. Do not hesitate to ask the technician all your questions. Before you use the stairlift, make sure that you understand all procedures.
- Keep the manual near the stairlift for easy reference. Save the phone number of the service centre in or near your phone.
- Make sure you carry a call device with you when using the stairlift.
- The stairlift is only intended for use by adults who have fully read and understood the manual.
- Make sure that there is enough illumination at the surroundings of the halt points for safe step-on and step-off the stairlift.
- Minors and users with an intellectual disability can only use the stairlift under supervision.
- Keep children away from the stairlift. Do not let children play with the stairlift.
- Do not use the stairlift for the transport of more than one person at the same time.
- Do not use the stairlift when your weight is more than the maximum permitted weight: 125 kg (275 lbs).
- Do not stand on the footrest when getting on or off the stairlift.
- When getting on or off the stairlift make sure the armrest are in a locked position.
- Do not get off the stairlift in between halt points.

2.1.2 STAIRS AND STAIRLIFT

- Do not use the stairlift in case of fire or near explosive materials.
- Keep water and moisture away from the stairlift.
- Do not use the stairlift to transport animals. Keep animals away from the stairs and the stairlift.
- Do not use the stairlift to transport goods. Keep goods away from the stairs and the stairlift.
- Before use, inspect the stairs and the stairlift. Only use the stairlift when the stairs are free of obstacles. Make sure that there are no obstacles on the rail.
- Make sure that loose clothing cannot become caught in the moving parts of the stairlift.
- Do not stand, but always sit on the seat.
- Always wear the safety belt.
- Remain seated upright during the ride. Do not lean back or forward. Do not make any unnecessary movements.
- Keep your arms and hands on the armrests.
- Keep your feet on the footrest. Do not let your feet protrude outside the footrest.
- Do not get off the stairlift on the stairs, not even in case of a breakdown. Only get off the stairlift at floor positions.
- In case of a breakdown, use the emergency lowering button. In case this fails, use the Communication Module (optional), or call device.
- Carefully fold or unfold any parts of the stairlift.
- Do not physically force the stairlift to start moving.
- Park the stairlift at a parking point to make sure that the batteries remain charged. The stairlift stops when it arrives at a parking point. If you do not park the stairlift at a parking point, a continuous sound indicates that the batteries may run out.
- Report unusual sounds or vibrations to your supplier immediately.
- In case of an emergency, press the emergency stop button in the joystick user interface. The stairlift will not operate when the emergency stop button is activated. Only de-activate the emergency stop button when the dangerous situation has been resolved.
- Keep the mains cable connected to the wall outlet to make sure that the batteries remain charged and the stairlift is ready for use.

2.1.3 MAINTENANCE

- Only carry out maintenance which is described in the user manual. See chapter 5 “Maintenance”.
- An authorised technician must carry out maintenance and repairs which are not described in the manual.
- In order to keep your lift safe and reliable, it is recommended to have it serviced annually by an authorised technician.
- Do not disassemble or repair the stairlift yourself. Have stairlift parts repaired and replaced by an authorised technician.
- Do not modify the stairlift in any way.
- Do not remove stickers, labels, data plates and warning plates from the stairlift.
- If you think that the stairlift has a defect which can cause injury or death, do not use the stairlift and immediately contact your supplier (see chapter 9).
- For North America: Do regular tests and inspections according to “ASME A18.1 - 2005: Safety Standard for Platform Lifts and Stairway Chairlifts”.

3 DESCRIPTION

3.1 STAIRLIFT

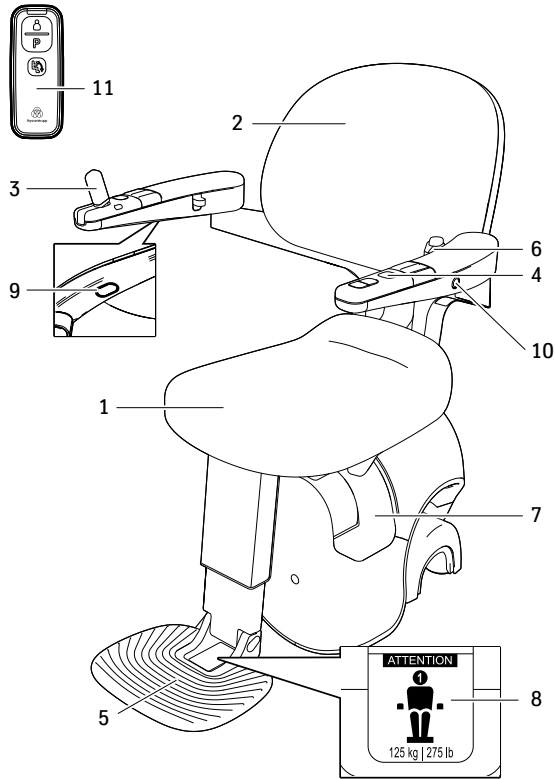

- | | |
|---|------------------------------|
| 1. Seat | 5. Footrest |
| 2. Backrest | 6. Safety belt |
| 3. Armrest with joystick user interface, emergency stop button and emergency lowering button | 7. Motor housing |
| 4. Armrest with options user interface (optional)
Available buttons depend on configuration. | 8. Warning plate |
| | 9. Emergency lowering button |
| | 10. Key lock (optional) |
| | 11. Call & Park control unit |

12. Main switch

Use the main switch to switch off the stairlift when it will not be used for two weeks.

- Operate the main switch to switch off the stairlift.
- Operate the main switch to switch on the stairlift.

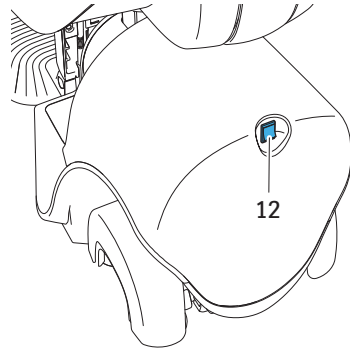

NOTE

If the lift is switched off with the on / off switch, the lift will still consume power and the battery will be empty after 2 days.



CAUTION

Only use the main switch to switch the stairlift on or off. Do not remove the mains plug from the wall socket. After use, the drive unit should always be parked at a charging point.

13. Status indicator

The status indicator shows the status of the stairlift.
See chapter 6 “Signals”.

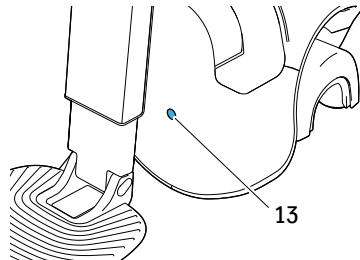

3.2 CONTROLS

3.2.1 JOYSTICK USER INTERFACE

Use the joystick to move the stairlift while you are seated in the chair.

14. Joystick

- Pull the joystick in upright position.
- Push and hold the joystick to the left or to the right to move the stairlift.
- Release the joystick to stop the stairlift.
- Fold down the joystick.

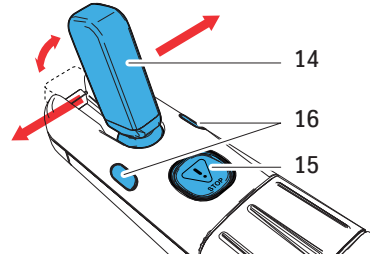

15. Emergency stop button

- See chapter 4.5 “Emergency stop”

16. Status indicator

- The status indicator shows the status of the stairlift.
See chapter 6 “Signals”.



NOTE

The attendant control has priority over the joystick user interface.

3.2.2 CALL-AND-PARK CONTROL STATIONS

Use the call-and-park control stations to move the stairlift while you are not seated in the chair. The call-and-park control stations are located at the top and the bottom of the stairs. As an option, the call-and-park control stations can also be located at intermediate floors with a parking point.

17. Call-and-park control station

18. Call button

- Push and hold the button to move the stairlift to you.
- After the stairlift stops, release the button.

19. Park button

- Push and hold the button to move the stairlift to the nearest parking point.
- After the stairlift stops, release the button.

20. Automatic seat folding button (optional)

- Press and hold the button for 1 sec. to fold or unfold the seat.

21. Status indicator

- The status indicator shows the status of the stairlift.
See chapter 6 “Signals”.

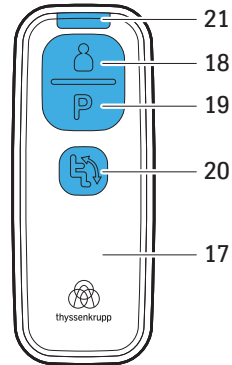

CAUTION

When the key lock is active the lift can still be operated via the call and park units.



NOTE

The stairlift will not move with the call-and-park-control stations if the emergency stop button is activated. The joystick user interface has priority over the call-and-park control stations.

22. Emergency lowering button

The emergency lowering button is located underneath the same armrest that holds the joystick user interface.

Use the emergency lowering button to let the stairlift descend if a malfunction occurs and the stairlift stops halfway along the rail.

- Push and hold the emergency lowering button to activate the descent system.
- The stairlift will start moving downwards at a reduced speed.
- Keep the emergency lowering button pressed until the stairlift has arrived at the nearest halt point to safely step-off.
- Release the emergency lowering button to stop the stairlift.



CAUTION

Only use the emergency lowering button in case of an emergency.

Immediately contact your supplier/ service provider to have your stairlift checked and repaired.



NOTE

In case the emergency lowering button doesn't function, any other call device carried by the user or our optional Communication Module can be used to call for help.

Do not get off the stairlift in between halt points.

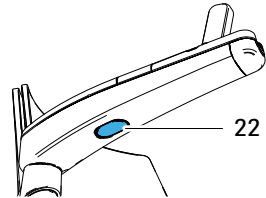
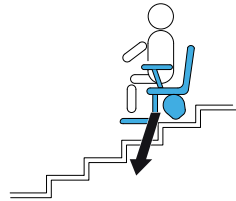

3.3 OPTIONAL FEATURES

3.3.1 ATTENDANT CONTROL STATION

The Attendant Control Station can be used to have an attendant to move the stairlift while the user is seated in the chair.

23. Ascend button

Press and hold the button to raise the lift while the user is seated in the chair.

24. Descend button

Press and hold the button to lower the lift while the user is seated in the chair.

25. Status indicator

The status indicator shows the status of the stairlift.

See chapter 6 “Signals”.

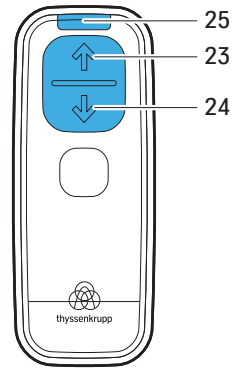

NOTE

When the key lock is active the attendant control station is blocked.

3.3.2 SWIVEL SEAT

To sit down and stand up safely and easily, the stairlift can be fitted with an automatic swivel seat.

3.3.2.1 AUTOMATIC PARKING SWIVEL SEAT

The automatic parking swivel will make the chair rotate at the bottom and/or top of the staircase, to make it easier to get on and off the stairlift.

Before you sit down or stand up, the chair will automatically turn into the required direction when you control the stairlift with the joystick user interface or the call-and-park control station.

3.3.2.2 FULL ENROUTE SWIVEL SEAT



The stairlift is equipped with the patented ASL (Advanced Swivel and Leveling) technology that makes the chair rotate and stay level. The technology offers the user maximum comfort. The swivel points of the chair are individually programmed in such a way that the user is always in the best possible seating position. The simultaneous movement of the swivel and leveling module keeps the chair in a horizontal position, independent of the angle the rail is inclining or declining.

Additional stops and swivel moments during the ride are avoided. The chair rotation at the bottom or top of the staircase makes it easier to get on and off the stairlift. With the ASL technology, the stairlift can be installed in small and narrow staircases while making sure that other persons can still walk the stairs. Remodeling work at the staircase is not necessary.

Before you sit down or stand up, the chair will automatically turn into the required direction when you control the stairlift with the joystick user interface or the call-and-park station. The chair can also turn backwards when you go upstairs and forward when you go downstairs.

Instructions

Sitting down

1. Push the call button on the call-and-park control station to call the chair to the Halt position and turn the chair into the boarding position.
2. Turn both armrests to the open position (position 3, see 4.1.1) until you hear and feel that the armrests are locked.
3. Unfold the seat.
4. Sit down on the chair.
5. Unfold the footrest.
6. Fasten the safety belt.
7. Put the armrests in position 2 (45 degrees inwards (depending on configuration) see 4.1.1).
8. Pull the joystick in upright position, then push and hold it to the left or to the right to move the stairlift. The chair will turn into the riding position and start moving.

3.3.4 AUTOMATIC FOOTREST FOLDING

By pressing the corresponding button on the armrest for more than 1 second will cause the green light on the joystick user interface to flash and a beep will sound. This will fold the footrest in or out automatically.



NOTE

When folding the seat, the footrest will always be folded as well.

However, unfolding the seat will not automatically unfold the footrest. Unfolding the footrest will always require a user action.

12. Options user interface

13. Automatic footrest folding button

Press the button for more than 1 sec. to fold or unfold the footrest.

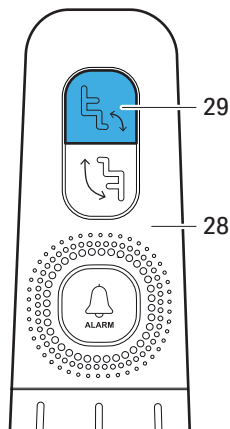

3.3.5 COMMUNICATION MODULE

To answer an incoming telephone call or to call for help in case of an emergency, the stairlift can be fitted with a Communication Module.

The Communication Module is connected to a DECT telephone base station and is operated by 1 button, located in the armrest opposite the joystick user interface. It works on a rechargeable battery that is charged by the drive unit.

An incoming call can be answered by shortly pressing the alarm button (+/- 1sec.). In addition, 3 telephone numbers can be pre-programmed in the Communication Module. When the alarm button is pressed for more than 4 seconds, the first programmed number will be dialled. To dial the next number, press the alarm button once again shortly (+/- 1sec.). Pressing the alarm button for more than 4 seconds will end the emergency call loop.

The button's LED indicators indicate the status of the Communication Module.

14. Communication Module

15. Alarm button

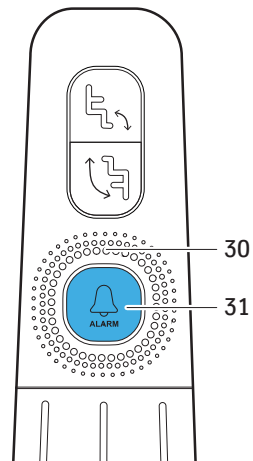

3.3.6 KEY LOCK (OPTIONAL)

The key lock makes it possible to put the stairlift in and out of operation with a key, e.g. when the stairlift is installed in a public area or to prevent children from playing with the stairlift.

Using key lock

The key lock is a pulse switch. After use, it returns to its original position. The key must be removed after use.

1. Insert the key.
2. Turn the key clock wise to unlock the stairlift (3 seconds green led + warning sound).
3. Turn the key clock wise again to lock the stairlift (3 seconds of orange led + Warning sound).
4. Remove the key after use. (to prevent unauthorized usage or damage to the stairlift).

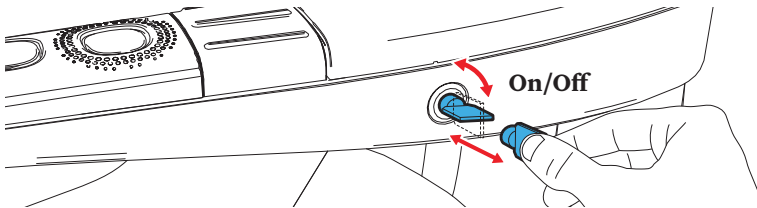

NOTE

When operated, the key lock switches ON the stairlift. After 5 minutes of inactivity, the sleep mode is activated and the stairlift is locked.



CAUTION

When the key lock is active the lift can still be operated via the Call-and-park control station.

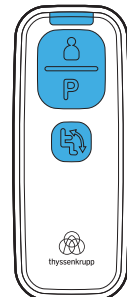

3.3.7 4-POINT SAFETY BELT (OPTIONAL)

When using the 4-point safety belt for the first time, please follow these steps. After the initial adjustment of the straps, it is only necessary to loosen and tighten the shoulder straps to use the safety belt. An attendant could help to make the adjustments at first use.

First use of the 4-point safety belt

1. Loosen all adjustable straps.
2. Sit down on the seat.
3. Move the shoulder straps over the shoulders.
4. Adjust the back strap until the cross point is on a comfortable place on the back and the belt fits naturally over the shoulders.
5. Fasten the 4 point safety belt.
6. Adjust the belt parts on the front side by pulling the straps until they are tight, but comfortable.
7. Adjust the shoulder parts by pulling the straps.



WARNING

Make sure that no loose ends can interfere with any moving parts.

8. Also fasten the standard safety belt if the stairlift is equipped with safety belt detection (see 4.3 for more information)
9. Now you can use the stairlift.

Remove the 4-point safety belt

1. Release the standard safety belt and the 4 point safety belt.
2. If necessary, loosen the shoulder straps.
3. Take off the 4 point safety belt.
4. When the chair is not in use, fold the seat and fold in the armrests.



CAUTION

Make sure that no loose ends can interfere with any moving parts in case that the stairlift will be moved by the Call-and-park control station.

Regular use of the 4-point safety belt

1. Sit down on the seat.
2. Move the shoulder straps over the shoulders.
3. Fasten the 4 point safety belt.
4. Adjust the shoulder straps and make sure that no loose ends can interfere with any moving parts.
5. Also fasten the standard safety belt if the stairlift is equipped with safety belt detection (see 4.3 for more information).
6. Now you can use the stairlift.

3.3.8 LEG BELT FOR DISABLED PERSONS

The stairlift can be equipped with a leg belt for disabled persons.

7. Leg belt for disabled persons

4 USE

4.1 UNFOLDING THE SEAT AND SITTING DOWN

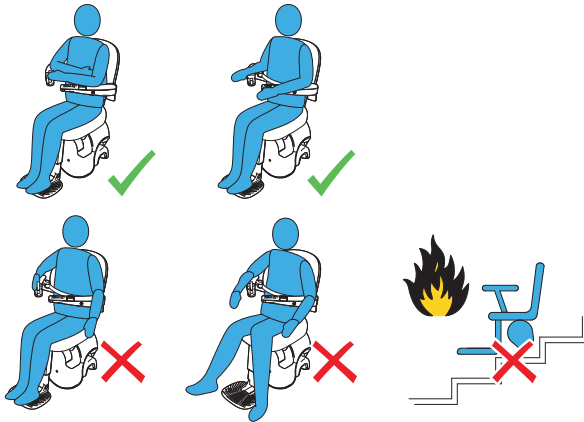

WARNING

When sitting down, take care for unintended operation of the Emergency Stop Button and folding buttons.

When getting on or off the stairlift make sure the armrests are in a locked position.



NOTE

Depending on the configuration of your stairlift, position 3 can also be the driving position.

4.1.1 ARMREST POSITIONS

The Flow X is equipped with patented angular armrest detection. This means the lift will not ride when the armrests are not in the correct and safe position.

Slide the sliders to unlock the armrests and position it (see 4.1.2 image 3).

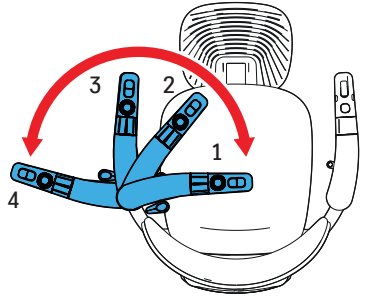

Both armrests have 4 positions:

- Pos. 1 for easy & compact folding
- Pos. 2 for comfortable & safe feeling during the ride
- Pos. 3 for easy & intuitive standing up/sitting down
- Pos. 4 for 'wheelchair transfer' (optional)



NOTE

Depending on the configuration of your stairlift, position 3 can also be the driving position.

4.1.2 CHAIR WITH AUTOMATIC SEAT AND FOOTREST FOLDING



WARNING

When operating the auto folding functions, watch out for moving parts like seat and footrest.

Do not use the sliders when performing the actual transfer. This is to avoid that the armrest will be unexpectedly unlocked.

If the chair is equipped with automatic seat and footrest folding, use the corresponding buttons on the armrest to unfold the chair and the footrest or use the call-and-park folding button.



NOTE

In case of a malfunction, the status indicator on the joystick user interface will show the status of the stairlift.

See chapter 6 “Signals” for more information.

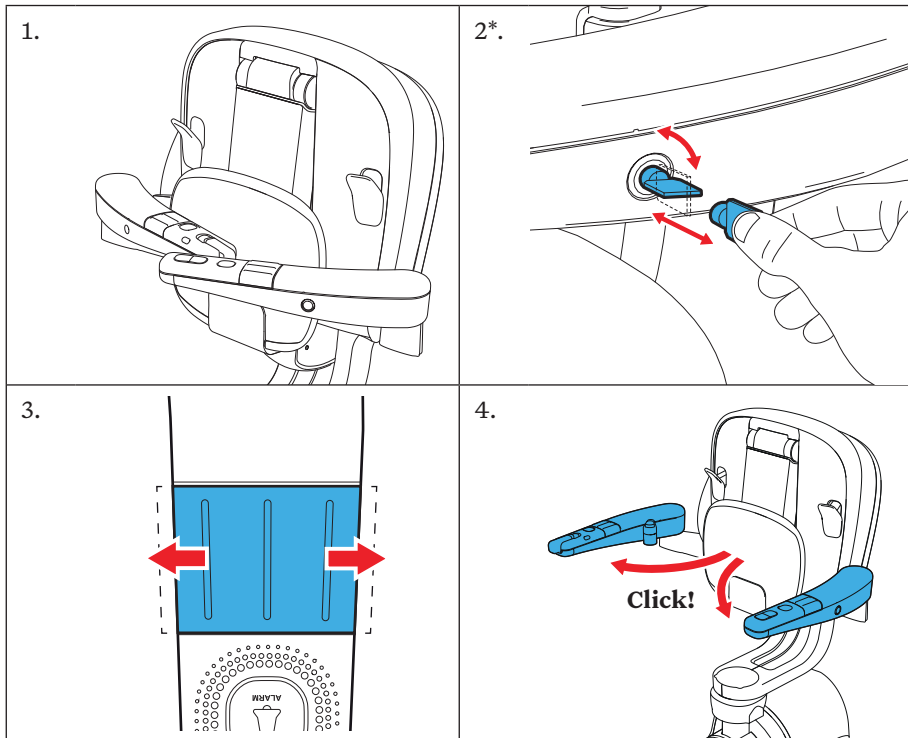

* Depending on configuration

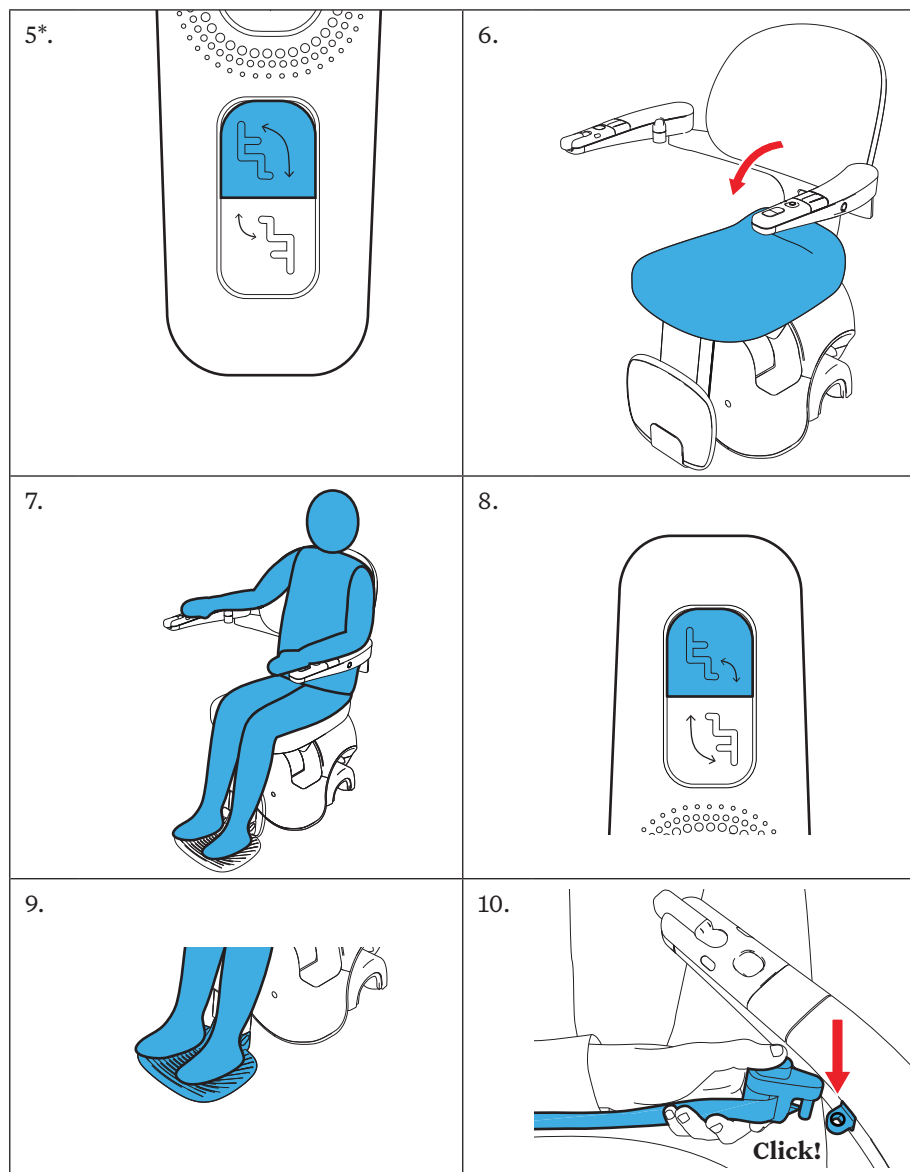

* Depending on configuration

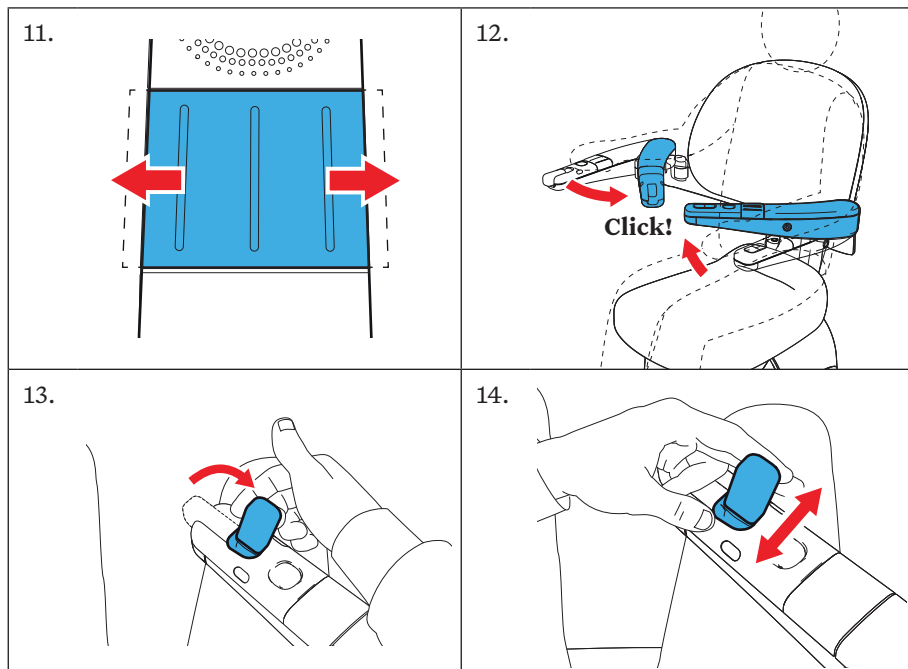

* Depending on configuration

4.1.3 CHAIR WITH MANUAL SEAT AND FOOT REST FOLDING (AUTOMATIC FOOT REST FOLDING OPTIONAL)

If the chair is equipped with manual seat folding: Pull or push the seat down in horizontal position to unfold the chair.

If the chair is equipped with manual footrest folding: While seated, use the levers underneath the seat to unfold the footrest. The footrest can also be flipped down by hand.



WARNING

Do not use the sliders when performing the actual transfer. This is to avoid that the armrest will be unexpectedly unlocked.



NOTE

In case of a malfunction, the status indicator on the joystick user interface will show the status of the stairlift.
See chapter 6 “Signals” for more information.

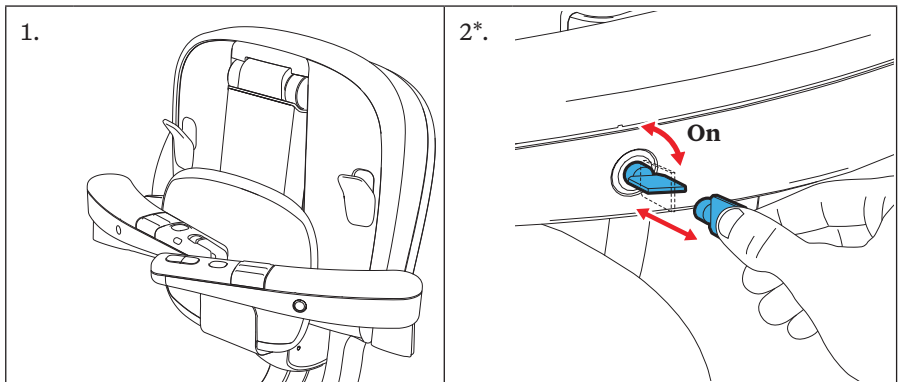

* Depending on configuration

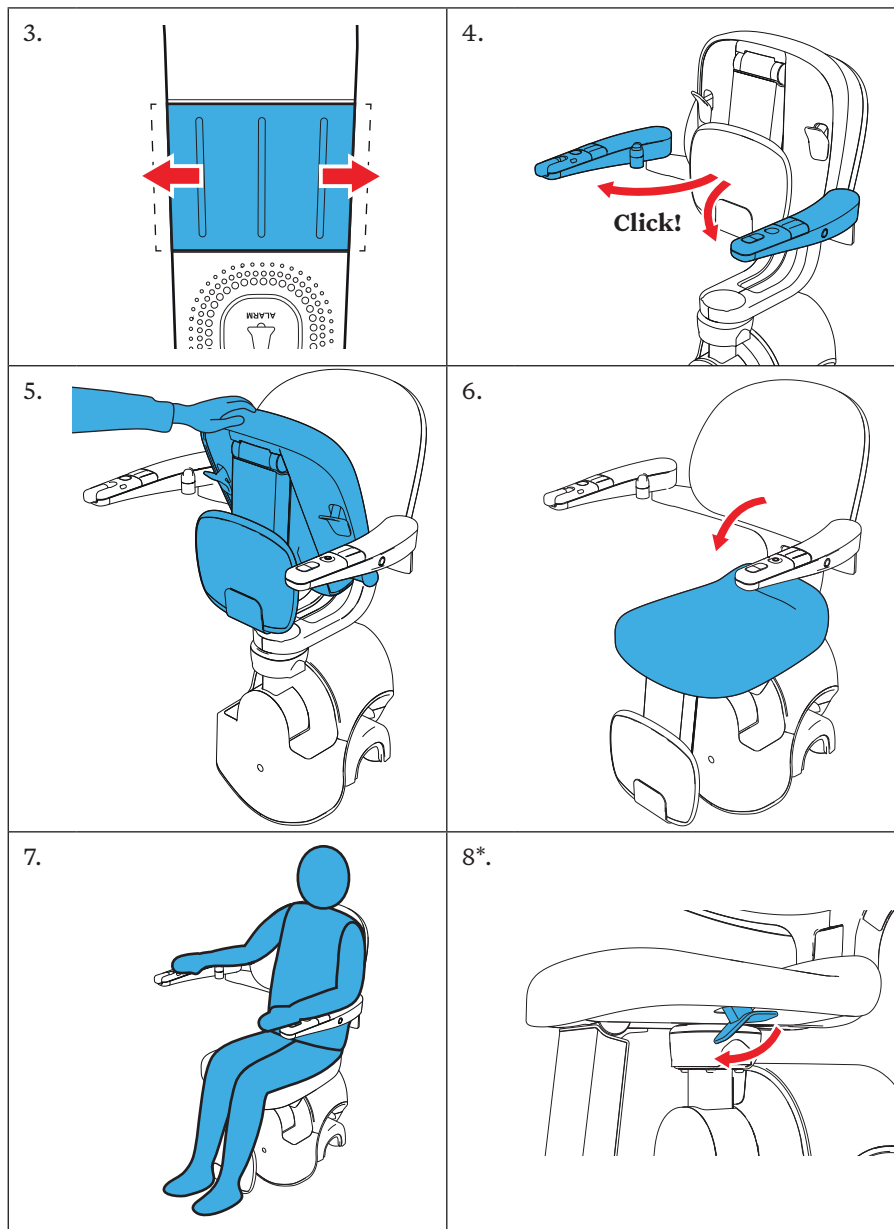

* Depending on configuration

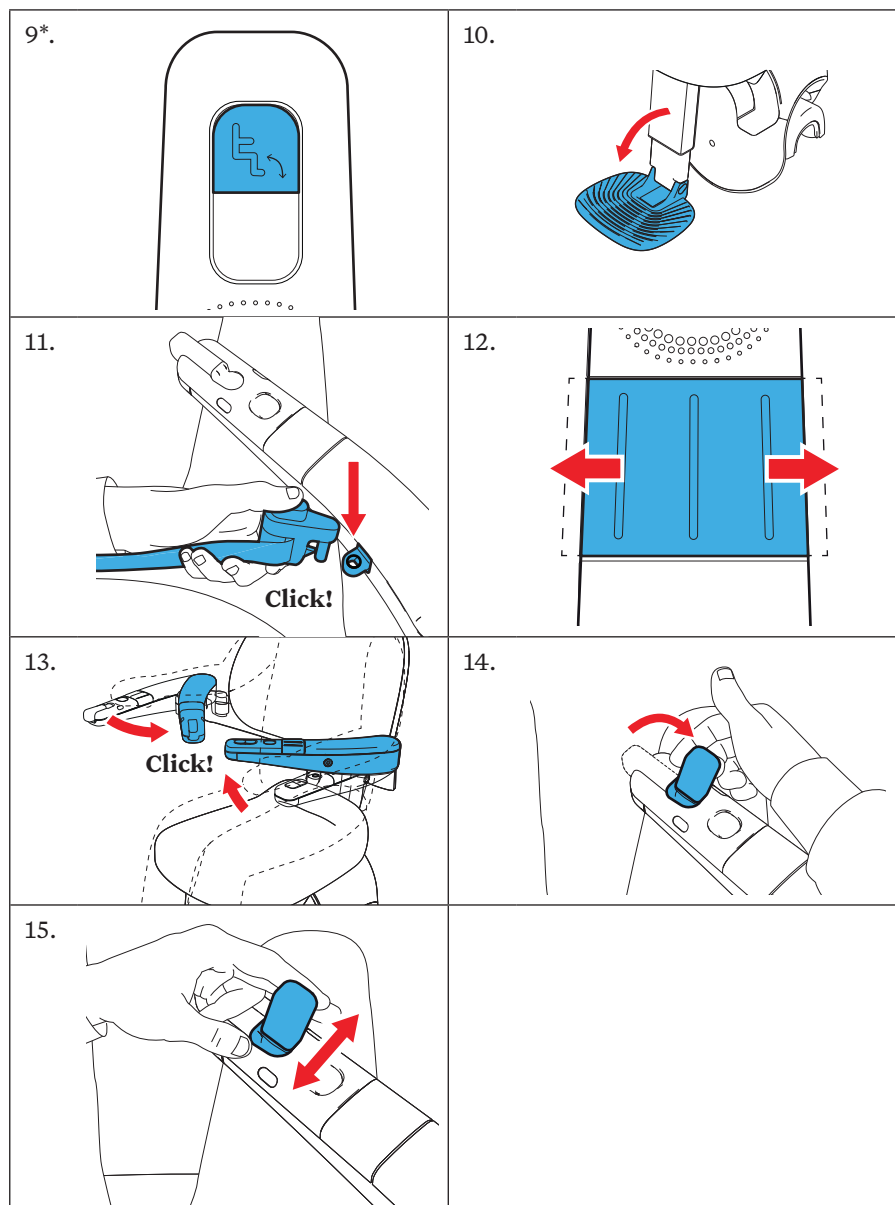

* Depending on configuration

4.1.4 CHAIR WITH WHEELCHAIR TRANSFER (OPTIONAL)

For easy transfer from a wheelchair the Flow X can be equipped with wheelchair transfer.



WARNING

When transferring from the wheelchair to the stairlift make sure that both armrests are locked to enable a safe transfer.



WARNING

Do not use the sliders when performing the actual transfer. This is to avoid that the armrest will be unexpectedly unlocked.



WARNING

When transferring at the top landing, make sure the armrest at the stairs side is securely locked in position 2 (see 4.1.1) and forms a secure barrier.

1. Position the armrest in position 4 (see 4.1.1).
2. Take place on the seat.
3. Fasten the safety belt.
4. Position the armrest in position 2 (or 3 depending on configuration) (see 4.1.1).

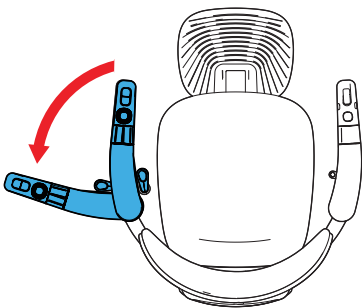

4.2 ADJUSTING THE SAFETY BELT

The safety belt is self-adjusting but can also be adjusted manually if necessary (see image).

1. Remove the cap from the buckle.
2. Unroll the end of the belt ribbon.
3. If the belt ribbon needs to be shortened, insert the belt retractor ribbon into the buckle and feed it through the buckle.
4. If the belt ribbon needs to be extended, feed the end of the ribbon through the buckle.
5. Roll the end of the belt ribbon into the recess in the buckle.
6. Refit the cap on the buckle.

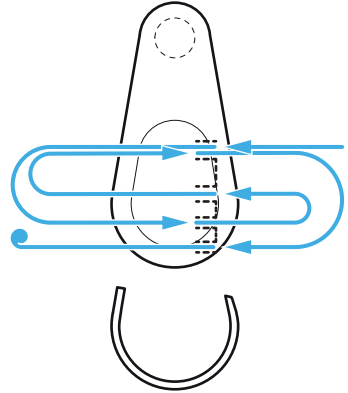

Detecting the safety belt (optional)

For models that are equipped with safety belt detection, the stairlift detects if the safety belt is fastened or not.



WARNING

Do not omit function of the safety belt detection by putting any object in the safety belt engagement eye, other than the safety belt buckle.



NOTE

If the stairlift is equipped with safety belt detection and the safety belt is not fastened, the stairlift cannot be operated with the joystick user interface or attendant control. The stairlift can only be operated with the call-and-park station.

4.3 TRAVELLING WITH THE STAIRLIFT

**NOTE**

Always operate the stairlift with the hand opposite of the joystick user interface.

I.e.: If the joystick user interface is positioned in the right side armrest, operate the stairlift with your left hand and vice versa.

1. Push and hold the joystick on the joystick user interface to the left or to the right to move the stairlift. The status indicator on the joystick user interface shows the status of the stairlift.

See chapter 6 “Signals”.

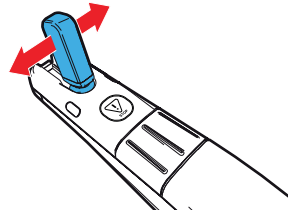
**NOTE**

If you release the joystick, the stairlift will stop immediately. The status indicator on the joystick user interface goes off. You can start the stairlift again only after a short delay.

2. The stairlift will stop at all halt points. To start moving again, release the joystick and then push and hold it to the left or to the right to move the stairlift.
3. Release the joystick to stop the stairlift.

4.4 EMERGENCY STOP



WARNING

Do not get of the stairlift on the stairs, not even in case of a breakdown. Only get of the stairlift at floor positions.



CAUTION

The stairlift will not operate when the emergency stop button is activated.

1. To stop the stairlift in case of an emergency, press the emergency stop button on the armrest.
2. The stairlift can be operated again after the emergency stop button is pressed again. There is a waiting time of 2 seconds after the first activation of the ESB.
3. See chapter 6 “Signals” for more information.

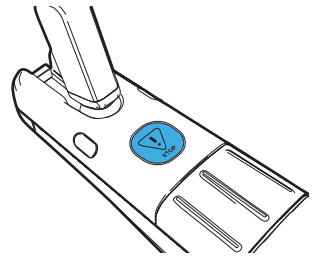

4.5 COMMUNICATION MODULE (OPTIONAL)

The Communication Module (CM) is an optional function. This option makes it possible to communicate via a landline with up to three pre-programmed telephone numbers, for example in case of an emergency.

Incoming calls can also be accepted.

4.5.1 MAKING A CALL

1. Press the yellow alarm button for 4 to 7 seconds. The dialling tone can now be heard.
2. Release the alarm button. The light on the alarm button has now turned green.
3. If the contact answers, you can communicate by speaking in the direction of the alarm button.

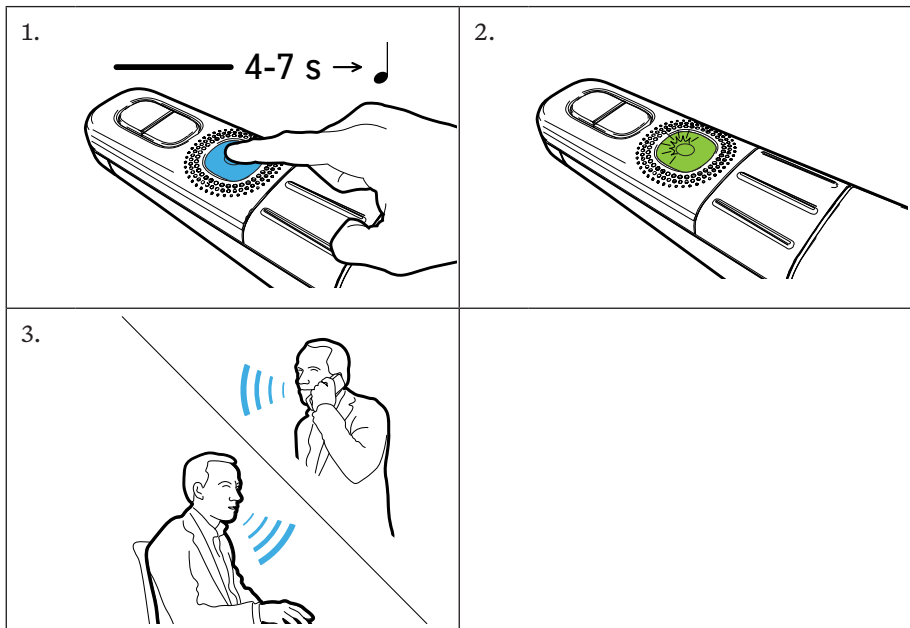

4.5.2 DISCONNECTING

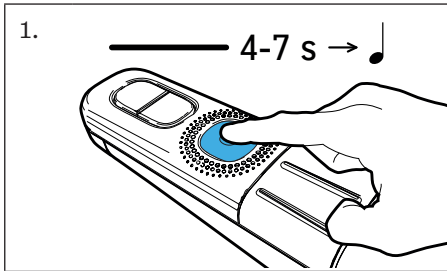

1. Press the yellow alarm button for 4 to 7 seconds. The light on the alarm button turns off.

The call has now ended. It is also possible for the person being called to hang up.

4.5.3 CHOOSING THE NEXT NUMBER

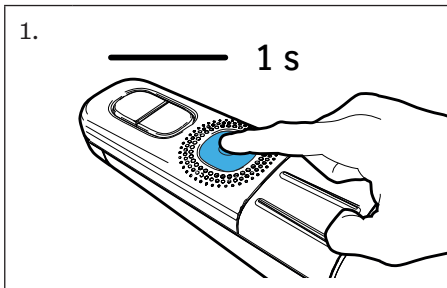

If the connection to the first contact does not succeed, you can choose to go to the next pre-programmed number. This is done as follows:

1. During the call, press the yellow alarm button once briefly. The next number will now be dialed.



NOTE

If the contact's number redirects to voice mail, you must also briefly press the yellow alarm button once to call the next number.

4.5.4 ACCEPTING INCOMING CALLS

The landline is connected to the Communication Module. An incoming call can therefore also be accepted while using the stairlift.

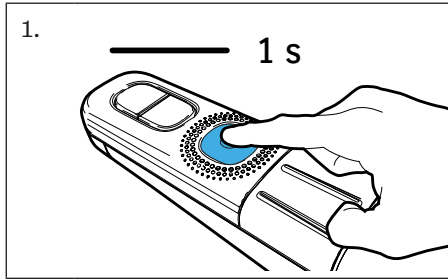

When there is an incoming call, the Communication Module produces a ring tone. Accepting the call is done as follows:

1. Briefly press the yellow alarm button once. The connection is now established. Speak in the direction of the alarm button to communicate.

The call can be ended by pressing the yellow alarm button for 1 second.

4.5.5 ERROR CODES

LED colour	Sound	Cause
Flashing red	None	Not connected to a base station or no base station selected
Flashing red	Two short beep sounds, not repeating.	CM power supply is lost or backup battery is charging
Flashing green	Two beep sounds, repeating every 2 minutes	The CM tries to reconnect to the registered base station
When calling, flashing red	Two beep sounds, 1 second pause, two beep sounds, not repeating	No telephone numbers programmed
Green (after trying to call)	None	No telephone line present

For other questions, please contact your supplier.

4.6 STANDING UP AND FOLDING THE SEAT

4.6.1 CHAIR WITH AUTOMATIC SEAT AND FOOTREST FOLDING (OPTIONAL)

If the stairlift is equipped with automatic seat and footrest folding, use the corresponding buttons on the armrest to fold the chair and the footrest.



WARNING

Do not use the sliders when performing the actual transfer. This is to avoid that the armrest will be unexpectedly unlocked.



NOTE

By folding the seat, the footrest will automatically be folded as well.

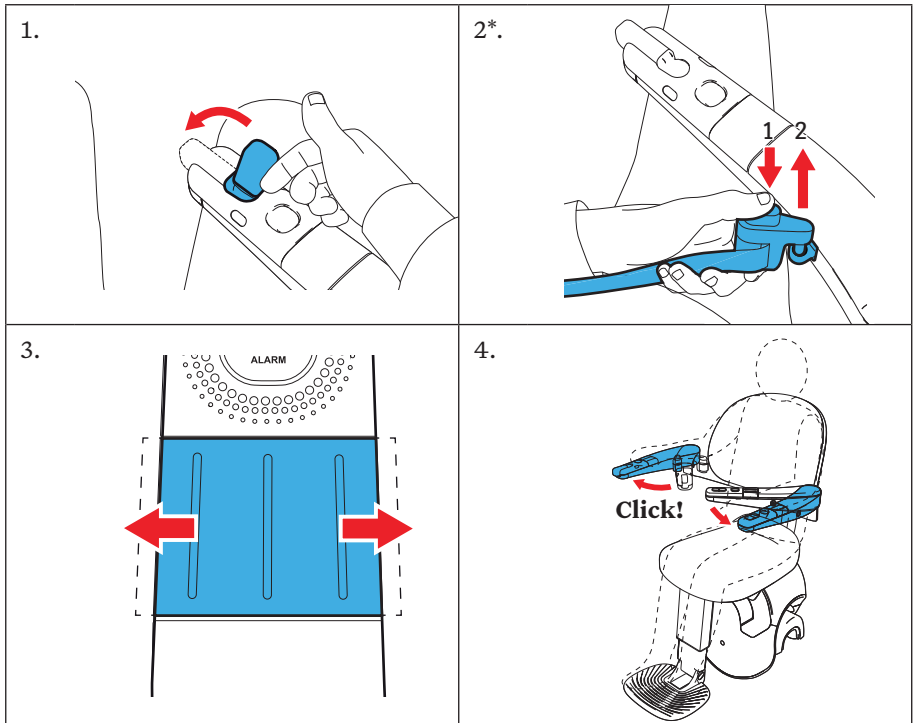

* Depending on configuration

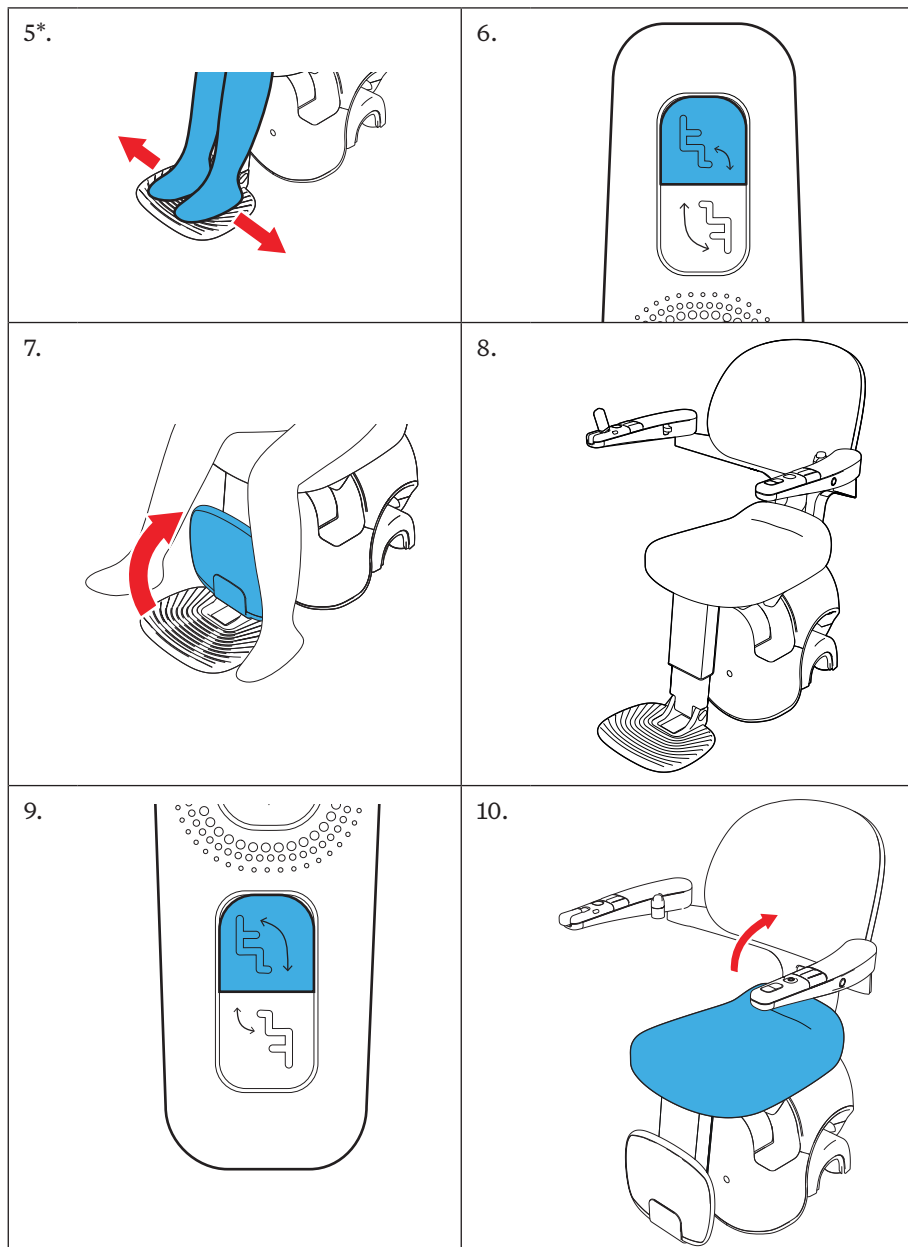

* Depending on configuration

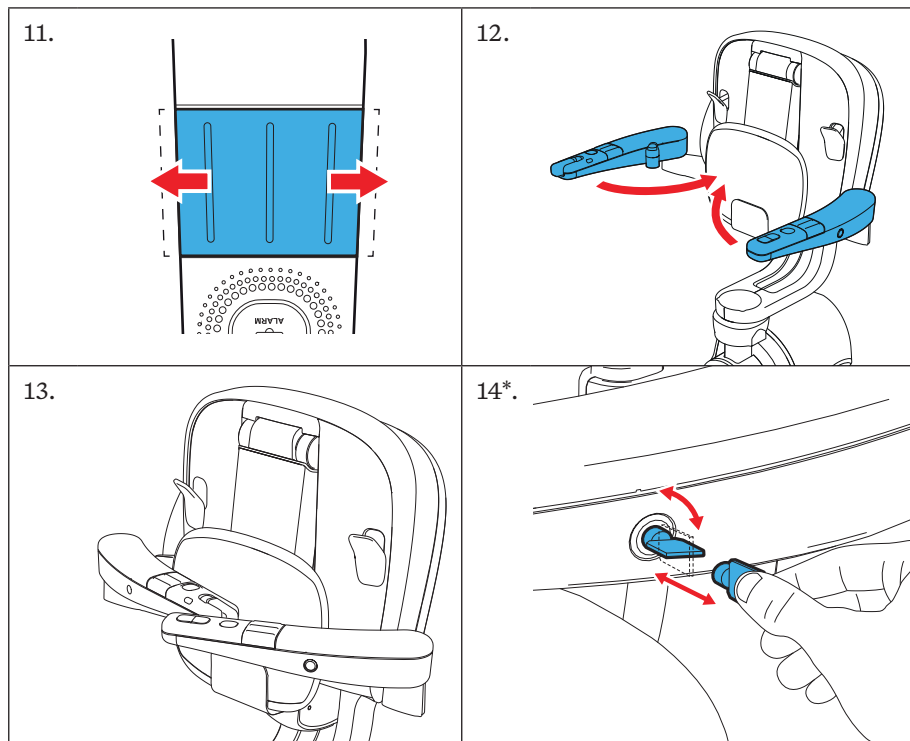

* Depending on configuration

4.6.2 CHAIR WITH MANUAL SEAT AND FOOT REST FOLDING (AUTOMATIC FOOT REST FOLDING OPTIONAL)

If the stairlift is equipped with manual seat folding, lift the front of the seat and put it in vertical position to fold the chair.



WARNING

Do not use the sliders when performing the actual transfer. This is to avoid that the armrest will be unexpectedly unlocked.



NOTE

By folding the seat, the footrest will automatically be folded as well.

The footrest can also be folded with the lever underneath the seat (while seated) or put in upright position by hand

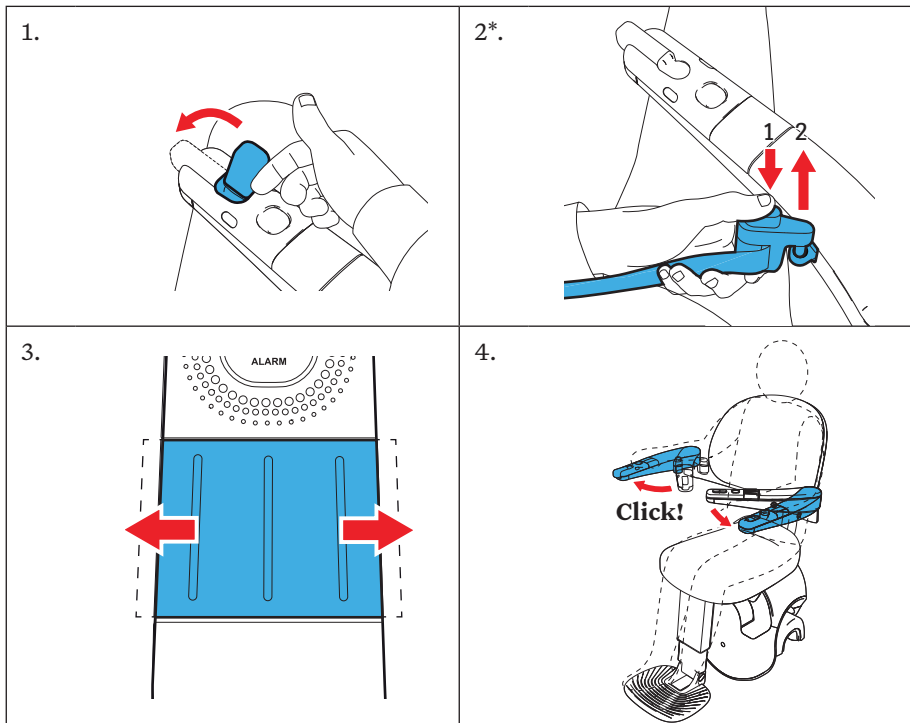

* Depending on configuration

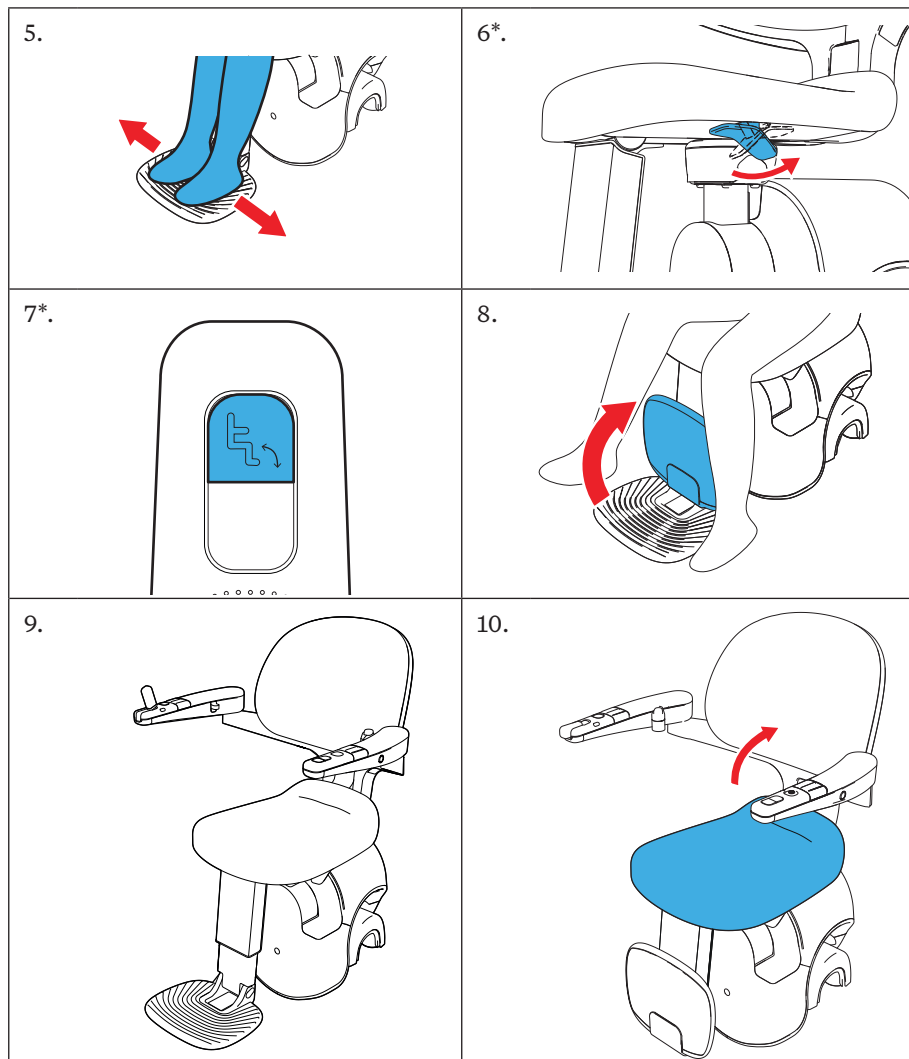

* Depending on configuration

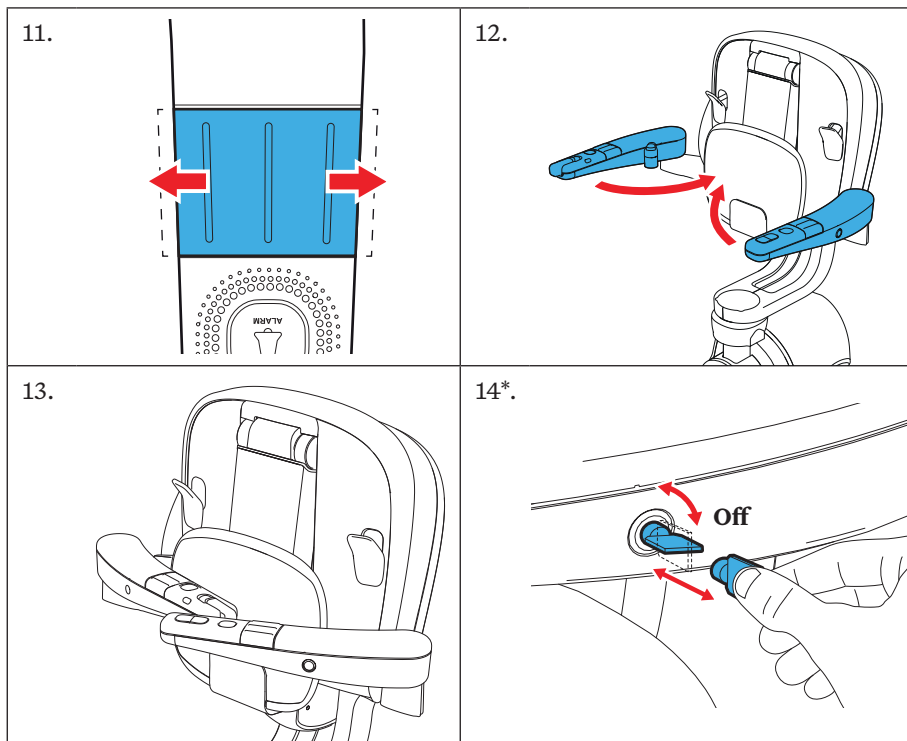

* Depending on configuration

5 MAINTENANCE

5.1 CLEANING THE STAIRLIFT

- Regularly clean the stairlift - seat, backrest, armrest, footrest, -safety belt, motor housing - with a soft, damp cloth. If necessary, use a mild detergent.
- Keep the joystick user interfaces and the call-and-park stations free of dirt.
- Regularly remove dust from the stairs and the rail with a damp cloth.

5.2 REGULAR MAINTENANCE

To keep your stairlift in the best condition, it is strongly recommended that it is annually serviced by an authorized service company.



NOTE

Instruction for Emergency lowering is an action in the Service list of the mechanic.

During service, the following items will be inspected and tested:

- Safety functions (emergency lowering button, safety belt etc.)
- Moving parts (armrest pivots, folding of seat etc.)
- Electronics (batteries, cabling etc.)
- Drive (covers, motor etc.)
- Rail (fixations, grease etc.)

An authorized technician is in possession of the complete service checklist.

5.3 REPLACING THE BATTERIES OF THE CALL-AND-PARK STATIONS/ATTENDANT CONTROL

The call-and-park stations use 4 AAA batteries. The lift indicates (flashes orange when used) when the batteries need to be replaced (see chapter 6 Signals).

If the battery is low and you push one of the buttons, the status indicator flashes orange, but the lift will continue to work. We strongly advice to change the batteries as soon as possible. If the battery runs out even further, the status indicator flashes red and the drive stops.

1. Remove the screw in the lower part of the wall mount, and open the battery compartment at the backside of the call and park control station/attendant control.
2. Replace the batteries.
3. Mount in reverse order to close the call-and-park control station (install the screw fixation).



NOTE

After you have replaced the batteries, purchase new spare batteries as soon as possible.

6 SIGNALS

6.1 SIGNALS ON MOTOR HOUSING

Signal	Meaning	Action
Constant blue light	The stairlift is switched on.	-
Constant blue light – slightly dimmed	The stairlift is in sleep mode on a parking point	-
No light	The stairlift is in sleep mode, but not on a parking point	Move the stairlift to a parking point
No light	The stairlift is switched off.	Switch on the stairlift by operating the main switch

6.2 SOUND SIGNALS FROM MOTOR HOUSING

Signal	Description
Arrival sound	Double beep
Emergency lowering sound	Double beep, every second
Start sound	Double beep
Warning sound	Fast intermittent beeps
Error sound	Intermittent beeps (of 2800 Hz to 7 KHz)

6.3 SIGNALS ON JOYSTICK USER INTERFACE

6.3.1 SIGNALS WHEN OPERATING THE STAIRLIFT

Signal	Meaning	Action
Constant green light	The joystick has been operated and the stairlift is moving.	-
Constant green light + start sound	The joystick has been operated and the stairlift starts moving	-
Blinking green light for 5 seconds + arrival sound	The stairlift has arrived at the halt point	Release the joystick and fold it down
Blinking green light for 5 seconds	The stairlift doesn't move: the joystick is pushed in the direction of the halt point where the stairlift is already located (end of the rail)	Push and hold the joystick in the other direction to start the stairlift
Blinking green light and warning sound when folding	The seat or footrest is being folded or unfolded	-
Constant orange light + warning sound	Not all conditions are met: the stairlift does not start These failures can be resolved by the user	Check and meet all conditions: <ul style="list-style-type: none"> - chair and footrest completely unfolded - armrests locked in correct position - safety belt fastened - Key lock in locked state Operate the joystick twice to start the stairlift
Constant orange light + warning sound	The anti-squeeze safety function is activated because the stairlift has encountered an obstacle and has stopped	Move the stairlift in the opposite direction to a parking point. Before you use the stairlift, make sure that the stairs are free of obstacles
Blinking orange light 2 times	Attendant control or emergency lowering button is active	-

Signal	Meaning	Action
Blinking orange light + warning sound	Emergency lowering button active when a malfunction has occurred	-
Blinking red light + warning sound	Emergency stop button is activated	Deactivate the emergency stop button by pressing the button for more than 2 seconds.
Constant red light + error sound	Malfunction	Switch the stairlift off and on again. If the stairlift does not respond, contact your supplier. If the situation occurs when the stairlift is in the middle of the stairs, descend with the emergency lowering button.

6.3.2 SIGNALS WHEN OPERATING THE EMERGENCY LOWERING BUTTON

Signal	Meaning	Action
Constant green light + emergency lowering sound	The emergency lowering button has been operated and if all the user setting preconditions are met, the stairlift is moving or starts moving	-
Constant orange light + emergency lowering sound	The emergency lowering button has been operated and the stairlift is moving or starts moving while the seat belt is not fastened	
Blinking green light for 5 seconds + arrival sound	The stairlift has arrived at the halt point	Release the emergency lowering button
Constant red light + error sound	Malfunction	Switch the stairlift off and on again. If the stairlift does not respond, contact your supplier
Blinking red light + warning sound	Emergency stop button is activated	Deactivate the emergency stop button

6.3.3 SIGNALS WHEN OPERATING THE KEY LOCK

Signal	Meaning
3 seconds of orange led + Warning sound	Key lock activation
3 seconds green led + warning sound	Key lock de-activation

6.4 SIGNALS ON CALL-AND-PARK STATION

Signal	Meaning	Action
Blinking green light + start sound (from stairlift drive)	The call-and-park button has been operated and the stairlift starts moving	-
Blinking green light for 5 seconds + arrival sound (from stairlift drive)	The stairlift has arrived at the halt point	Release the call-and-park button
Blinking orange light + warning sound (from stairlift drive)	Not all conditions are met: the stairlift does not start.	Check and meet all conditions: <ul style="list-style-type: none"> - armrests locked in correct position - safety belt fastened - key lock in status locked
Blinking orange light 2 times	Joystick or emergency lowering button is active	-
Blinking orange light	The call-and-park battery is low	Replace the batteries
Blinking red light + error sound	Malfunction	Switch the stairlift off and on again. If the stairlift does not respond, contact your supplier.
Blinking red light + warning sound	Emergency stop button is activated	Deactivate the emergency stop button

7 TECHNICAL DATA

Maximum permitted weight	125 kg (275 lbs)
Driving speed (nominal)	0,1 m/s (20 ft/min)
Sound pressure level	67 dB(A) Electrical system

Electrical system

Power supply	class 2
Input	100-240 VAC, 50/60 Hz, 1.7 A
Output	36VDC, 72W

Environmental conditions

Ambient temperature	-5 - 40 °C (23 - 104 °F)
Relative humidity	20 - 80%

Batteries (stairlift drive)

Battery type	NP7-12LFR / NP7-12TFR: 12 V
Number of batteries	2
Charging time	16 hours
Capacity	10 journeys (125 kg (275 lbs), 1 floor height, vertical start downstairs, horizontal stop upstairs)

Batteries (call and-park station and attendant control)

Battery type	AAA: 1.5 V
Number of batteries	4

1001771A



Manufacturer

thyssenkrupp Stairlifts B.V.

Van Utrechtweg 99, 2921 LN

P.O. Box 754, 2920 CB Krimpen aan den IJssel (The Netherlands)

Phone: +31 (0)180 530 900

E-mail: info.stairlifts@thyssenkrupp.com

Internet: www.thyssenkrupp.com